

Distribution of Pathogenicity Islands in *Salmonella* spp.

HOWARD OCHMAN¹ AND EDUARDO A. GROISMAN^{2*}

Department of Biology, University of Rochester, Rochester, New York, 14627,¹ and Department of Molecular Microbiology, Washington University School of Medicine, St. Louis, Missouri 63110²

Received 25 July 1996/Returned for modification 26 September 1996/Accepted 3 October 1996

We investigated the phylogenetic distribution of the SPI-1 and SPI-2 pathogenicity islands in *Salmonella* spp. SPI-1 was present in representatives of all eight subspecific groups, but no SPI-2-hybridizing sequences were detected in group V (*S. bongori*). Our data suggest that SPI-2 was acquired by *S. enterica* after its split from *S. bongori*.

Virulence properties in bacterial pathogens are often mediated by genes contained within pathogenicity islands, i.e., large, unstable segments of the chromosome that are not present in related nonpathogenic organisms (2, 13, 15, 21). Two pathogenicity islands have been identified in the chromosome of *Salmonella enterica* serovar typhimurium. The first, designated SPI-1, governs the ability of salmonellae to enter mammalian epithelial cells (8, 16); the second, designated SPI-2, is required for the survival of salmonellae within macrophages (18, 22). Both islands are approximately 40 kb in length (16, 22) and appear to have been acquired by horizontal gene transfer because their GC contents are lower than those typical of genes from salmonellae (11).

Because pathogenicity islands can be acquired and deleted from bacterial genomes, we have examined the distribution and ancestry of the SPI-1 and SPI-2 regions in *S. enterica*. SPI-1 is situated at 63' on the *S. enterica* serovar typhimurium LT2 chromosome, and genes from this region are present in representative strains from all subspecific groups (I to VII) of *S. enterica* (7, 14). A phylogenetic tree based on *inv* and *spa* genes from the SPI-1 island is congruent with that of several house-keeping genes, indicating that these invasion-associated sequences were acquired prior to the diversification of all extant serovars of *S. enterica* and have not been subject to subsequent transfer among strains (14). Certain strains of serovars litchfield and senftenberg apparently lack sequences hybridizing to

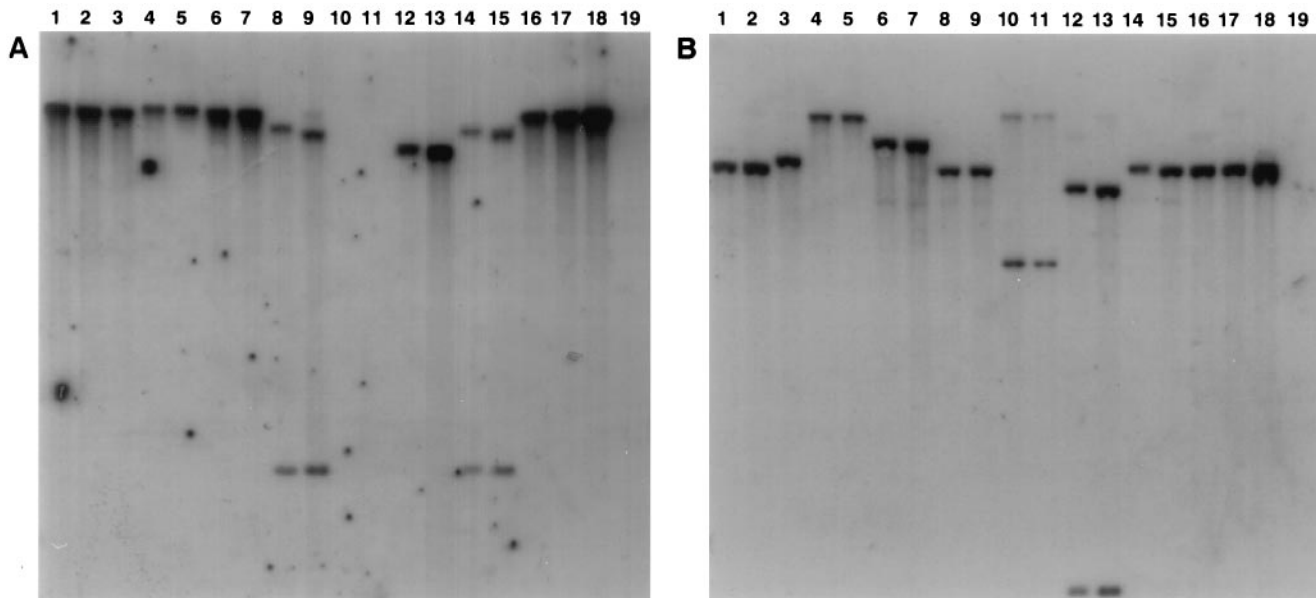

FIG. 1. Phylogenetic distribution of SPI-2 (A) and SPI-1 (B) sequences. Southern hybridization experiments were performed as described previously (11) with chromosomal DNA from *Salmonella* strains s4194, s3333, s2993, s2980, s2983, s2978, s2979, s3015, s3027, s3041, s3044, s2995, s3057, s3013, and s3014 from *Salmonella* Reference Collection C (4), *S. enterica* serovar enteritidis strain s53 and *S. enterica* serovar Dublin strain s1518 (3), *S. enterica* serovar typhimurium strain 14028 (6), and *E. coli* K-12 strain MC1061 (5) (lanes 1 to 19, respectively). The ³²P-labeled 5.7-kb *Bam*HI fragment from plasmid RF333 and the 6.4-kb *Bam*HI fragment from plasmid RF319 (7, 11) were used as probes (A and B, respectively).

* Corresponding author. Mailing address: Department of Molecular Microbiology, Washington University School of Medicine, 660 S. Euclid Ave., Campus Box 8230, St. Louis, MO 63110. Phone: (314) 362-3692. Fax: (314) 362-1232. Electronic mail address: groisman@borcim.wustl.edu.

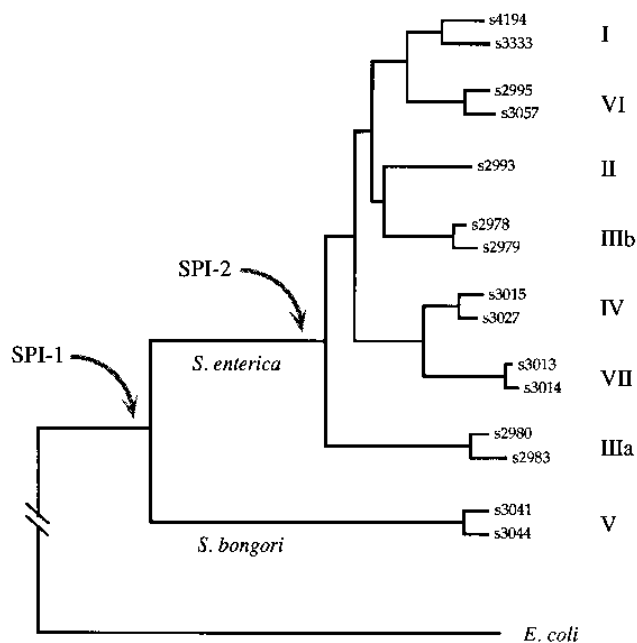

FIG. 2. Evolutionary relationships of *Salmonella* Reference Collection C strains based on variation in the nucleotide sequences of five housekeeping genes (4). Strain numbers refer to those described in the legend to Fig. 1, and the eight groups are designated by roman numerals.

invA (19); however, a PCR-based assay of *invA* from 29 independently isolated strains typed to serovar senftenberg (s2298, s2354, s2356 to s2360, s2362, s2363, s2366 to s2374, s2378, s2383 to 2385, and s2387 to s2393) provided no evidence of a deletion from any other strain tested (data not shown). The prevalence of this gene within serovar senftenberg suggests that strains lacking *invA* are not characteristic of this serovar but, rather, represent sporadic cases of secondary loss.

In contrast to SPI-1, which contains a large set of genes having sequence and functional homologs in other invasive enteric pathogens (1, 9, 10, 12), sequences from the SPI-2 island appear to be restricted to salmonellae (7, 11). (Note that SPI-2 corresponds to clone RF333 described in these previous publications.) Given its distribution among enteric bacteria and its role in *Salmonella* virulence, we anticipated that the SPI-2 pathogenicity island would be present in all strains and subspecies of the genus *Salmonella* but this is not the case.

EcoRI-treated chromosomal DNAs of *Salmonella* strains from *Salmonella* Reference collection C (4) were electrophoresed through 0.8% agarose gels, transferred to nylon membranes, and probed with a ³²P-labeled 5.7-kb *Bam*HI fragment encompassing four genes, *spiA*, *spiB*, *spiC*, and *spiR*, situated in the SPI-2 pathogenicity island. Representative strains of groups I, II, IIIa, IIIb, IV, VI, and VII (which constitute *S. enterica*) contained sequences that hybridized to this probe (Fig. 1A); however, no signal was detected in DNA prepared from strains s3041 and s3044 from group V (*S. bongori*). In contrast, a probe containing nine *spa* genes, *spaLMNOPQRST*, from SPI-1 hybridized to the DNAs of all eight *S. enterica* subspecies (Fig. 1B). As previously demonstrated (11), no signal was detected in *Escherichia coli* K-12 hybridized with either probe.

On the basis of multilocus enzyme electrophoresis analysis and the nucleotide sequences of 12 genes from *Salmonella* Reference Collection C strains, *S. bongori* is the most divergent form of salmonellae (4), which has led to its classification as a

species distinct from *S. enterica* (20). The most parsimonious explanation for the hybridization pattern detected in the present study is that the SPI-2 pathogenicity island is ancestral to *S. enterica*, acquired after its split from *S. bongori* but prior to the diversification of groups I, II, IIIa, IIIb, IV, VI, and VII (Fig. 2).

The SPI-2 island maps to the 31' region of the *S. enterica* serovar typhimurium LT2 chromosome. It harbors at least 15 genes that code for a type III secretion apparatus, similar to those detected in other animal and plant pathogens (17, 23), and for a two-component regulatory system (18, 22). Unlike SPI-1, which also codes for a type III secretion system and regulatory proteins, the SPI-2 region is not necessary for the invasion of host cells but is needed for intramacrophage survival (18). Thus, by conferring the ability to invade epithelial cells, evade host defense systems, and cause systemic infections in mammals, the acquisition of both SPI-1 and SPI-2 pathogenicity islands was critical in the development of salmonellae as an intracellular pathogen. In this regard, it is perhaps not surprising that *S. bongori* s3041 and s3044 were isolated from nonmammalian hosts, a frog and a bird, respectively. We are currently investigating whether such strains, which lack SPI-2 sequences, are capable of surviving in macrophage cell lines and provoking lethal infections in mammalian hosts.

We thank Felix Solomon for technical assistance.

This research was supported by grants from the National Institutes of Health (GM-54900 and GM-48407). E.A.G. is a recipient of a Junior Faculty Research Award from the American Cancer Society.

REFERENCES

- Bergman, T., K. Erickson, E. Galyov, C. Persson, and H. Wolf-Watz. 1994. The *lcrB* (*ycsN/U*) gene cluster of *Yersinia pseudotuberculosis* is involved in Yop secretion and shows high homology to the *spa* gene clusters of *Shigella flexneri* and *Salmonella typhimurium*. *J. Bacteriol.* **176**:2619-2626.
- Blum, G., M. Ott, A. Lischewski, A. Ritter, H. Imrich, H. Tschäpe, and J. Hacker. 1994. Excision of large DNA regions termed pathogenicity islands from tRNA-specific loci in the chromosome of an *Escherichia coli* wild-type pathogen. *Infect. Immun.* **62**:606-614.
- Boyd, E. F., F.-S. Wang, P. Beltran, S. A. Plock, K. Nelson, and R. K. Selander. 1993. *Salmonella* reference collection B (SARB): strains of 37 serovars of subspecies I. *J. Gen. Microbiol.* **139**:1125-1132.
- Boyd, E. F., F.-S. Wang, T. S. Wittam, and R. K. Selander. 1996. Molecular genetic relationships of the salmonellae. *Appl. Environ. Microbiol.* **62**:804-808.
- Casadaban, M. J., and S. N. Cohen. 1980. Analysis of gene control signals by DNA fusion and cloning in *Escherichia coli*. *J. Mol. Biol.* **138**:179-207.
- Fields, P. I., R. V. Swanson, C. G. Haidaris, and F. Heffron. 1986. Mutants of *Salmonella typhimurium* that cannot survive within the macrophage are avirulent. *Proc. Natl. Acad. Sci. USA* **83**:5189-5193.
- Fitts, R. 1985. Development of a DNA-DNA hybridization test for the presence of *Salmonella* in foods. *Food Technol.* **39**:95-102.
- Galán, J. E. 1996. Molecular genetic bases of *Salmonella* entry into host cells. *Mol. Microbiol.* **20**:263-272.
- Ginocchio, C. C., and J. E. Galán. 1995. Functional conservation among members of the *Salmonella typhimurium* InvA family of proteins. *Infect. Immun.* **63**:729-732.
- Groisman, E. A., and H. Ochman. 1993. Cognate gene clusters govern invasion of host epithelial cells by *Salmonella typhimurium* and *Shigella flexneri*. *EMBO J.* **12**:3779-3787.
- Groisman, E. A., M. A. Sturmoski, F. R. Solomon, R. Lin, and H. Ochman. 1993. Molecular, functional, and evolutionary analysis of sequences specific to *Salmonella*. *Proc. Natl. Acad. Sci. USA* **90**:1033-1037.
- Hermant, D., R. Ménard, N. Arricau, C. Parsot, and M. Y. Popoff. 1995. Functional conservation of the *Salmonella* and *Shigella* effectors of entry into epithelial cells. *Mol. Microbiol.* **17**:781-789.
- Lee, C. A. 1996. Pathogenicity islands and the evolution of bacterial pathogens. *Infect. Agents Dis.* **5**:1-7.
- Li, J., H. Ochman, E. A. Groisman, E. F. Boyd, F. Solomon, K. Nelson, and R. K. Selander. 1995. Relationship between evolutionary rate and cellular location among the Inv/Spa invasion proteins of *Salmonella enterica*. *Proc. Natl. Acad. Sci. USA* **92**:7252-7256.
- McDaniel, T. K., K. G. Jarvis, M. S. Donnenberg, and J. B. Kaper. 1995. A genetic locus of enterocyte effacement conserved among diverse enterobacterial pathogens. *Proc. Natl. Acad. Sci. USA* **92**:1664-1668.

16. **Mills, D. M., V. Bajaj, and C. A. Lee.** 1995. A 40 kilobase chromosomal fragment encoding *Salmonella typhimurium* invasion genes is absent from the corresponding region of the *Escherichia coli* K-12 chromosome. *Mol. Microbiol.* **15**:749–759.
17. **Ochman, H., and E. A. Groisman.** 1995. The evolution of invasion by enteric bacteria. *Can. J. Microbiol.* **41**:555–561.
18. **Ochman, H., F. C. Soncini, F. Solomon, and E. A. Groisman.** 1996. Identification of a pathogenicity island required for *Salmonella* survival in host cells. *Proc. Natl. Acad. Sci. USA* **93**:7800–7804.
19. **Rahn, K., S. A. De Grandis, R. C. Clarke, S. A. McEwen, J. E. Galán, C. Ginocchio, R. d. Curtiss, and C. L. Gyles.** 1992. Amplification of an *invA* gene sequence of *Salmonella typhimurium* by polymerase chain reaction as a specific method of detection of *Salmonella*. *Mol. Cell. Probes* **6**:271–279.
20. **Reeves, M. W., G. M. Evins, A. A. Heiba, B. D. Plikaytis, and J. J. Farmer III.** 1989. Clonal nature of *Salmonella typhi* and its genetic relatedness to other salmonellae as shown by multilocus enzyme electrophoresis and proposal of *Salmonella bongori* comb. nov. *J. Clin. Microbiol.* **27**:313–320.
21. **Ritter, A., G. Blum, L. Emödy, M. Kerenyi, A. Böck, B. Neuhierl, W. Rabsch, F. Scheutz, and J. Hacker.** 1995. tRNA genes and pathogenicity islands: influence on virulence and metabolic properties of uropathogenic *Escherichia coli*. *Mol. Microbiol.* **17**:109–121.
22. **Shea, J. E., M. Hensel, C. Gleeson, and D. W. Holden.** 1996. Identification of a virulence locus encoding a second type III secretion system in *Salmonella typhimurium*. *Proc. Natl. Acad. Sci. USA* **93**:2593–2597.
23. **Van Gijsegem, F., C. Gough, C. Zischek, E. Niqueux, M. Arlat, S. Genin, P. Barberis, S. German, P. Castello, and C. Boucher.** 1995. The *hly* gene locus of *Pseudomonas solanacearum*, which controls the production of a type III secretion system, encodes eight proteins related to components of the bacterial flagellar biogenesis complex. *Mol. Microbiol.* **15**:1095–1114.

Editor: P. E. Orndorff